



SERIES
RMB
HOT RUNNER CONTROLLER

*Instruction
Manual*



Athena Controls, Inc.
5145 Campus Drive
Plymouth Meeting, PA 19462
Phone: 610-828-2490
Fax: 610-828-7084
www.athenacontrols.com

You can reach our technical support team by phoning 1-800-782-6776 (from the United States) or 610-828-2490 (from anywhere in the world). The e-mail address for tech support is techsupport@athenacontrols.com

Athena® is a registered trademark of Athena Controls, Inc.

© 2003 Athena Controls, Inc. All rights reserved.

Precautions

Warning



Use of this equipment in a manner not specified by the manufacturer may impair protection provided by the equipment.

In addition to presenting a potential fire hazard, high voltage and high temperature can damage equipment and cause severe injury or death. When installing or using this instrument, follow all instructions carefully and use approved safety controls.

Hazardous potentials exist on components inside the mainframe and controller. Always disconnect AC power to the mainframe when servicing the controllers or the mainframe.

Because these temperature controls or associated equipment may not always fail safe, an approved temperature and/or pressure safety control should be used for safe operation.

The controller power switch must be in the “OFF” position before you put a controller into an energized mainframe, or remove a controller from an energized mainframe. If the mainframe supports the SafeChange[®] feature, enable SafeChange on the controller to reduce the possibility of damage to the controller when installing or removing a controller from the mainframe. Controllers are shipped with the SafeChange feature disabled. To determine whether the mainframe supports SafeChange and to enable SafeChange, follow the instructions in Section 0.

Turn off power to the controller before cleaning the exterior of the controller.

Failure to observe these precautions can result in exposure to a potentially lethal shock hazard.

Changing DIP switch and jumper settings, and all wiring should be done by an experienced technician. The controller and wiring should be installed in accordance with national and local electrical codes. To avoid serious personal injury and damage to equipment, follow all warnings and cautions provided in the manual supplied with the mainframe.

Littlefuse[®] is a registered trademark of Littlefuse, Inc.

Bussmann[®] is a registered trademark of Cooper Industries, Inc.

G SERIES[™] is a trademark of D-M-E Company.

CompuStep[™], SafeChange[™], and G+[™] are trademarks of Athena Controls, Inc.

Caution



If a controller shows signs of having been damaged during shipping, do not power up or install the controller. Save all packing materials and report any damage to the carrier immediately.

When the controller is powered up, the output may be activated. Consider the effects on your process before powering up the controller.

We recommend placing the controller in standby mode before changing tuning parameter values manually. The output is off in standby mode.

Do not locate this instrument where it may be subjected to excessive shock, vibration, dirt, moisture, oil, or other liquids.

This is a Class A product. In domestic environments this product may cause radio interference in which case the user may be required to take adequate measures.

Specified operating ambient temperature is 32 to 131 °F (0 to 55 °C).



Notes on CE EMC Compliance

This unit is compliant with the following standards when properly installed into a grounded metal housing. EMC testing was conducted with a load of 1 amp and setpoint of 400 °F.

EMC directive (89/336/EEC)

EN 50081-1 (1992 edition)

EN 50082-1 (1992 edition)

Low Voltage Directive (73/23/EEC)

EN 61010-1 (1992 edition, Amendments 1, 2, 3, 4 and 11)

Table of Contents

Precautions	1
1. Introduction	1
1.1 About This Manual.....	1
1.2 Features and Benefits of RMB Controllers.....	1
1.3 Specifications.....	4
2. Operation	5
2.1 Front Panel.....	5
2.2 What Happens When You Power Up the Controller.....	6
2.3 Operation Basics.....	6
2.4 Manual Tuning.....	7
3. Enabling SafeChange and Setting Switches	9
3.1 Introduction.....	9
3.2 Checking Mainframe for SafeChange Capability.....	9
3.3 Enabling the SafeChange Feature.....	9
3.4 Adding a SafeChange Clip to the Mainframe.....	10
3.5 Factory Switch Settings.....	10
4. Setup and Installation	11
4.1 Prepare the Controller.....	11
4.2 Install the Controller.....	11
4.3 Apply Power to the Mainframe and Controller.....	11
4.4 Adjust the Setpoint.....	11
4.5 Wait for the Controller to Tune Itself.....	11
5. Error Messages and Codes	12
5.1 Introduction.....	12
5.2 Summary of Error Codes.....	12
5.3 Ground Fault in Controller Output Wiring.....	14
5.4 Loop Break in Sensor Wiring.....	14
5.5 Open Thermocouple.....	14
5.6 Reversed Thermocouple Leads.....	14
5.7 Heater Current Monitoring.....	15
5.8 Autotune Errors.....	15
6. Maintenance	16
6.1 Introduction.....	16
6.2 Cleaning the Front Panel.....	16
6.3 Replacing the Fuses.....	17
6.4 Unit Repairs.....	17

7. Frequently Asked Questions	18
7.1 Introduction.....	18
7.2 FAQs.....	18
Index	19

1. Introduction

1.1 About This Manual

This manual contains all the information needed to set up and operate the Series RMB Hot Runner controllers.

Instructions for wiring, installing, and troubleshooting the controllers are in the manual supplied with the mainframe.

1.2 Features and Benefits of RMB Controllers

1.2.1 Introduction

The Series RMB Hot Runner controllers offer many advanced features designed to increase productivity and ensure fast, accurate, and repeatable mode temperature control. Each unit is designed to control one temperature zone based on input from a J or K thermocouple. The controllers are set at the factory for J thermocouple input. To use a K thermocouple, change a switch setting; see 3.4.

1.2.2 Compatibility

The Series RMB Hot Runner controllers are physically and electrically compatible with all previous G SERIES and G+ mainframes, and with all existing Hot Runner controllers. Retrofit and replacement are fast and easy. Installation and setup instructions are in Section 4.

1.2.3 Convenient User Interface

RMB controllers are equipped with a bright two-line LED display that is easy to read over wide viewing angles.

The process value is displayed on the top line (three digits).

The lower line (four digits) displays your choice of setpoint (normal mode), output percentage (normal and manual), and output current to the closest tenth of an amp (normal and manual).

An orange LED on the front panel indicates heater on, and a red LED indicates high or low process alarm. Green LEDs signal current mode and boost action.

Front panel keys make it easy to change mode, change setpoint (normal mode), output % (manual mode), and to activate the boost. You can also use the front panel to change tuning parameter values.

RMB controllers with the optional 30 amp output TRIAC are wider than the 15 amp units (to accommodate the heat sink), but the user interface is the same.

Detailed instructions for using the front panel are in Section 2.

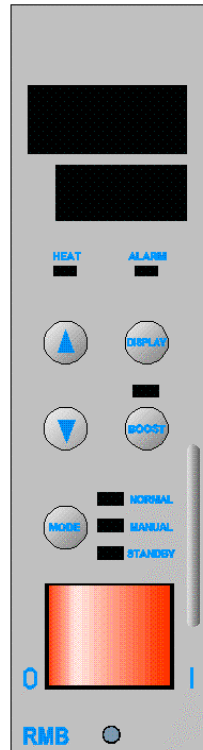

1.2.4 PID Control with Autotuning

In normal (automatic) mode each Series RMB controller uses a single TRIAC output to implement Proportional-Integral-Derivative (PID) control. Tuning is automatic.

By default, the Autotune operation is executed once. If the Autotune is successful, then Autotune is disabled. You can stop the Autotune by pressing the **MODE** key. This does not disable the Autotune feature. If Autotune operation is set to "once", then the controller attempts to perform the Autotune operation each time the controller is powered up, until a successful Autotune is completed.

You can disable Autotune entirely or enable it for every power up. To change the Autotune setting, use the **Pi d** menu. You can also use the **Pi d** menu to change the proportion band and rate manually; see 2.4.

1.2.5 CompuStep[®] Soft Start for Heater Bake Out

All Series RMB Hot Runner controllers support the CompuStep soft start feature to extend the life of the heaters and the molds. The soft start allows slow dissipation of moisture in heaters by gradually applying power to the heaters.

When a soft start is executed, phase angle firing starts at 5% output power and steps up the output 5% every 30 seconds. The soft start lasts five minutes or until the process temperature reaches 200 °F (93 °C).

The green **NORMAL** LED flashes during soft start in normal (auto) mode. You can stop the soft start by pressing the **MODE** key.

By default, a soft start is executed:

- every time the controller starts and the process value is less than 200 °F (93 °C), and
- every time the controller is returned to normal (automatic) operation and the PV is less than 200°F (93 °C).
- any time a ground fault is detected; see 1.2.7.6

You can set SW2-switch 1 to OFF as described in Section 3 to cause the controller to execute a soft start only in response to detection of a ground fault interruption. More information about the start up sequence is in 2.2.

1.2.6 Boost Function

Every Series RMB Hot Runner controller supports a boost function that is activated when you press the **BOOST** key. For the next 15 seconds (or until you press the **BOOST** key again, whichever is sooner), 20% more power is added to the controller output (100% output maximum).

1.2.7 Process Protection Features

1.2.7.1 Deviation Alarms

Each Series RMB Hot Runner controller supports two deviation alarms. If the process value falls below the setpoint minus 30 °F (17 °C), or if the process value exceeds the setpoint plus 30 °F (17 °C), the red **ALARM** LED on the front panel of the controller lights. The alarm status indicator remains lit as long as the process value deviates from the setpoint by at least 30 °F (17 °C).

1.2.7.2 Loop Break Detection

The controller monitors the input change. If the input value does not change within 999 seconds while the controller is operating in normal (automatic) mode and a “bad heater” error has not been detected (see 1.2.7.5), then the controller signals a loop break as described in 5.4 and the controller goes to manual mode with 0% output, which can then be adjusted.

1.2.7.3 Sensor Error Monitoring

The controller can detect a reversed sensor or open sensor. The controller action when a sensor problem is detected depends on the type of error and the mode of the controller; see 5.4 and 5.5 for details.

1.2.7.4 Heater Current Monitoring

The present current output to the heater, expressed to the closest tenth of an amp, is always displayable in the lower line. Cycle through the available lower line display items using the **DISPLAY** key.

1.2.7.5 Output Interruption Check

An RMB controller constantly checks heater current readings to ensure that they correlate with output activity. If a TRIAC short or bad heater is detected, the output failure interruption relay breaks the connection between the controller’s TRIAC output and the heater. An error message is also displayed; see 5.6.

1.2.7.6 Ground Fault Detection Circuit

An RMB controller can detect ground faults in the controller output. When a ground fault is detected, the controller attempts to perform a normal soft start, if the process value is less than or equal to 200 °F (93 °C).

The controller performs the soft start up to three times if necessary. If the ground fault is detected again after the soft start has been executed three times, the controller signals a “hard” ground fault; see 5.2.

1.2.8 Ease of Setup

DIP switches make it easy to change the input type and unit of measure. The defaults are J thermocouple, with degrees Fahrenheit for North America and degrees Celsius for other shipping destinations.

The controller tunes itself automatically. However, you can use the controller’s front panel to change the proportional band and rate manually; see 2.4.

1.3 Specifications

1.3.1 Operating Limits

Ambient Temperature 32 °F to 131 °F (0 °C to 55 °C)

Relative Humidity Tolerance 10 to 95 % Non-Condensing

Shipping Temperature -40 °F to 158 °F (-40 °C to 70 °C)

Power Requirements 115 to 240 Vac 50 or 60 Hz nominal, CE compliant

1.3.2 Performance

Accuracy ± 0.3 % of span

Setpoint Resolution 1 degree Fahrenheit

Repeatability ± 0.1 % of span

Temperature Stability ± 0.5 % of full scale over the ambient range of 32 °F to 131 °F (0 °C to 55 °C)

Thermocouple Cold-End Tracking automatic, better than 0.02 °F per °F (0.01 °C per °C)

Noise Rejection Common Mode > 100 dB, Series Mode > 70 dB

Process Sampling Rate 10 Hz (100 ms)

1.3.3 Connections and Mounting

The Series RMB controllers are designed for installation in a Hot Runner mainframe (or other compatible mainframe). Removal of an RMB controller from the mainframe requires removal of a locking pin (standard controllers) or locking screw (CE-compliant controllers).

1.3.4 Inputs

Thermocouple J or K

Supported Sensor Range 32 to 999 °F (0 to 537 °C)

1.3.5 Output

TRIAC, 15 amps at 120/240 Vac (30 amp optional), driven by optically isolated interface circuit. Protected with a pair of 15 amp (or one 30 amp) field-replaceable fuses. Instructions for replacing the fuses are in 6.3. Replacement fuses must be Type F fast-acting 250 Vac fuses rated at 15 amps (or 30 amps).

A 15 amp (120/240 Vac) relay (30 amp optional) interrupts power to the heater if the controller detects shorting of the TRIAC output or other system failures.

A ground fault detection circuit is also standard.

2. Operation

2.1 Front Panel

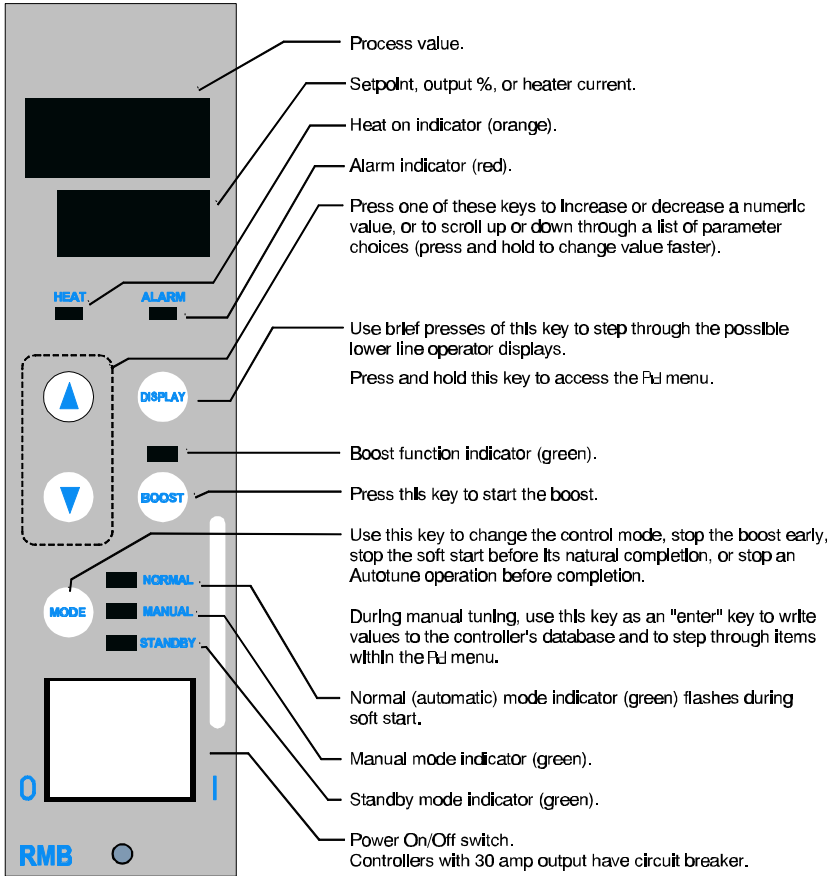

RMB controllers with the optional 30 amp output TRIAC are wider than the 15 amp units (to accommodate the heat sink), but the user interface is the same.

2.2 What Happens When You Power Up the Controller

Turn on the controller by pressing the “I” end of the 16 A power switch on the front panel. When an RMB controller is powered up, it lights all segments of the display briefly, then displays its firmware level.¹

The sequence of controller actions that follow and the state of the controller output depend on:

- **SW2-switch 1 setting** – If SW2-switch 1 is ON (the default), the controller does a CompuStep soft start if the process value is less than or equal to 200 °F (93 °C). If SW2-switch 1 is OFF, the controller does not do a soft start at power up.
- **PI d (PID control) menu’s At.OP (Autotune operation) parameter value** – If the value of At.OP the default once (once) or EnA (always enabled), Autotune is attempted.

You can stop soft start and Autotune by pressing the **MODE** key repeatedly.

2.3 Operation Basics

2.3.1 See PV

To see the process value: Look at the top line of the display for the PV. The top line shows the PV, unless the controller detects an error, or Autotune is active, or you are in the Pi d menu.

2.3.2 See if Output is On

To see if the output is on: Look at the HEAT LED. It is on when the output is on.

2.3.3 Monitor for Alarms

To watch for process alarms: Look at the red ALARM LED. If the process value falls 30 °F (17 °C) below the setpoint or increases to 30 °F (17 °C) above the setpoint, the ALARM LED lights. It stays lit as long as the PV deviates from the setpoint by at least 30 °F (17 °C).

2.3.4 Change Mode

To change the mode: Press **MODE** repeatedly until the LED lights for the mode you want. The modes are:

- **normal** (closed loop control) – Controller uses the input value to calculate the output needed to maintain the setpoint shown on the lower line.
- **manual** (open loop control) – Controller output is the percent shown on the lower line. Input is ignored. Transfer from normal to manual is “bumpless” when the process value is within 9 °F (5 °C) of the setpoint.
- **standby** – Standby output OP (zero percent) is on the lower line.

¹ It is a good idea to make a note of the firmware version number. If you phone for technical support, you will be asked for this version information, as well as for the complete model number of the controller in question.

2.3.5 View Setpoint, Output, and Current

To cycle through the lower line displays: Press the **DISPLAY** key repeatedly.

- In normal mode you can cycle through the setpoint, output percent (with P), and heater current to the closest tenth of an amp (with A).
- In manual mode you can switch between output percent (with P) and heater current to the closest tenth of an amp (with A).

2.3.6 Change Setpoint or Output

To change the setpoint (normal mode) or output (manual mode): Press **DISPLAY** until the setpoint or manual mode output is on display. Press the ▲ or ▼ key until the displayed value has been changed to the new value you want.

The output current value and normal mode output percentage are read-only.

2.3.7 Start Boost

To start the boost: Press the **BOOST** key. The LED above the **BOOST** key lights. For the next 15 seconds (or until you press the **BOOST** key again, whichever is sooner), 20% is added to the controller output (100% output maximum).

2.4 Manual Tuning

2.4.1 Usually Not Needed

Manual tuning is usually not necessary. By default an RMB controller Autotunes the first time it is powered up. If the Autotune is not successful, the controller will try to Autotune every time it is powered up until Autotune is successful. Autotune is then disabled automatically.

2.4.2 PID Control

With PID control the device modulates output power by adjusting the output power percentage within a proportional band. Power is proportionally reduced as the process temperature gets closer to the setpoint temperature.

The derivative action affects the output based on the rate of change of the process value.

You can use the **Pi d** menu to change the **Pb** (proportional band) and **rAtE** (derivative) values.

The integral action (reset) affects the output based on the duration of the process value's variation from the setpoint. In the Series RMC Hot Runner controllers, the integral (reset) action is always equal to five times the derivative (rate) action.

You can also use the **Pi d** menu to change the setting of the **At.OP** (Autotune operation) parameter, which determines when Autotuning is attempted.

2.4.3 Changing Tuning Parameters Values Manually

To change a tuning parameter value manually:

1. Put the controller in standby by pressing the **MODE** key until the STANDBY LED is lit.
2. Access the tuning menu by pressing and holding the **DISPLAY** key until **Pi d** is displayed on the top line (approximately 3 seconds).
3. Display the first parameter in the menu by pressing the **MODE** key. The second line of the display will show **Pb** (proportional band), the name of the first parameter in the menu, alternating with the current value.

Pi d alternating Pi d
pb with 24

4. If this is not the parameter you want to change, press **MODE** repeatedly until you see the parameter you want.
5. Use the ▲ and ▼ keys to change a numeric value or scroll through the choices.
6. When the desired choice or numeric value is on display, press the **MODE** key once. The displayed choice or value will be written to the controller's database. The next parameter in the menu (or the first parameter if you were at the end of the menu) will be displayed.

At this point you can:

- change the value of the newly displayed parameter with the ▲ and ▼ keys, or
- if you like the current value of the parameter on display, you can press the **MODE** key to leave the displayed value unchanged and go on through the parameters in the menu, or
- exit the **Pi d** menu by pressing and holding the **DISPLAY** key until the normal operating display returns to view, and then press **MODE** to return to normal mode.

If you do not press any key, eventually you will be timed out of the **Pi d** menu. The controller will revert to the operational display that was in view before you entered the menu. The value that was on display when you were timed out of the menu will be saved to the controller's database automatically.

2.4.4 Pi d Menu Parameters

Pb (proportional band) – Valid range is 0.1 to 999 °F (0 to 537 °C). Default is 24 °F (13 °C).

rATE (derivative) – The valid range is 0.0 to 999 seconds. Default is 7 seconds.

At.OP (Autotune operation) – Choices are:

- dI S Autotune disabled
- oNcE Autotune once at next power up, then disable if Autotune was successful.
- EnA Autotune enabled every time controller is powered up.

3. Enabling SafeChange and Setting Switches

3.1 Introduction

Controllers are shipped with SafeChange disabled, because the controller will not work if the SafeChange feature is enabled, but the mainframe does not support SafeChange. You can enable SafeChange quickly and easily using a jumper as described in this section.

Basic set up choices are made using DIP switches as described in this section. The switches in a Series RMB Hot Runner controller are set at the factory for J thermocouple as the input type, with Fahrenheit as the unit of measure for North America, and Celsius for other shipping destinations.

If you plan to use a K thermocouple for input and/or if you plan to display the process value and enter the setpoint in the unit of measure that is not the default for your location, you must change these switch settings.

Read and heed the warnings and cautions in the front of this manual before checking the mainframe for SafeChange capability or changing controller switch and jumper settings.

3.2 Checking Mainframe for SafeChange Capability

Do not enable SafeChange unless the mainframe supports this feature.

To check the mainframe for SafeChange capability:



1. Turn off power to the mainframe.
 2. Remove a blanking panel or a controller that is OFF, so you can look into the mainframe.
 3. Look at the lower connector block on the backplane (shown on next page).
- If a metal clip is in the third position in the connector block, then the mainframe supports

SafeChange. You should enable SafeChange on the controller before installing it in the mainframe to reduce the possibility of damage to the controller; see 3.3.

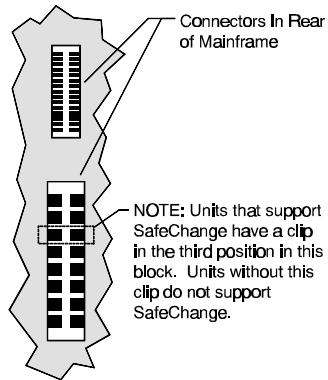

Location of Clip in Mainframe to Support SafeChange

Use of the SafeChange feature does not eliminate the need for careful installation and removal of controllers. Always turn off power to the controller and the mainframe when installing or removing a controller.

- If the third position in the connector block does not contain a metal clip, then the mainframe does not support SafeChange. You can add a clip to convert the mainframe; see 3.4.

3.3 Enabling the SafeChange Feature

Controllers are shipped with SafeChange disabled, because the controller will not work if the SafeChange feature is enabled, but the mainframe does not support SafeChange.

You can enable SafeChange quickly and easily.

To enable the SafeChange feature, remove the jumper block from JP6.

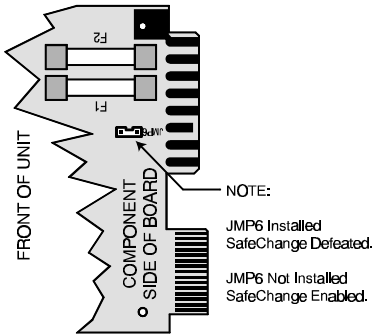

Location of SafeChange Jumper JP6

If you don't see JP6, the controller in hand may pre-date the SafeChange feature. In addition to JP6 in the location shown above, controllers that support SafeChange also have one edge connector shorter than the others. If all the edge connectors are the same length, the controller does not support the SafeChange feature.

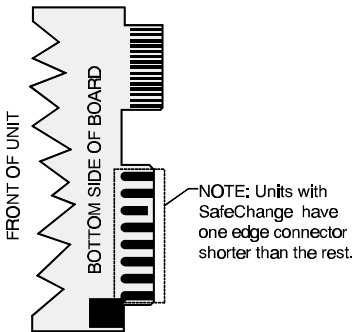

SafeChange Edge Connector

3.4 Adding a SafeChange Clip to the Mainframe

You can convert an older mainframe to support SafeChange. To make the conversion, you must add a clip to the third position in the lower connector block (on the backplane) in every slot; see the illustration in 3.2. The clip is p/n 216D001U01.

To install the clip:



1. Turn off power to the mainframe.
2. Remove the back cover of the mainframe.
3. Position the clip in the third (open) position in the lower connector block, and press. The clip will snap into position.

3.5 Factory Switch Settings

The factory switch settings are shown below.

SW2 SWITCHES SHOWN IN FACTORY DEFAULT POSITION FOR DOMESTIC UNITS (1 ON). FOR EXPORT UNITS, SWITCHES 1 (SOFT START) AND 3 (°F / °C) ARE ON. SWITCH 8 IS NOT USED

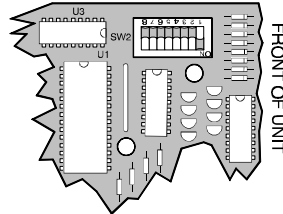

NOTE: Switch ON position is down towards the center of the board.

Location of DIP Switches

SW2-switch 1 – OFF for soft start only when ground fault has been detected; ON (default) for soft start every time controller is powered up.

SW2-switch 2 – OFF (default) for J thermocouple input; ON for K thermocouple.

SW2-switch 3 – OFF for degrees Fahrenheit; ON for degrees Celsius. Default depends on shipping destination: OFF for North America ON for all other destinations.

SW2-switch 5 – OFF (default) for normal operation; ON to load default parameter values the next time controller is powered up.

SW2-switch 4 is used only at the factory. SW2-switches 6, 7, and 8 are not used. Leave them off.

4. Setup and Installation

4.1 Prepare the Controller

1. Unpack the RMB controller.
2. Inspect the controller for damage.
3. Make sure the power switch on the front of the controller is set to off (O).

If a controller shows signs of having been damaged during shipping, do not install or power up the controller. Save all packing materials and report any damage to the carrier immediately.

4.2 Install the Controller

This guide assumes that the mainframe has already been wired as described in the installation manual supplied with the mainframe.

1. Make sure the plunger in center of the locking pin is pulled out (or loosen the locking screw).
2. With the controller and mainframe power switches set to off (O), align the RMB controller's printed circuit board with the guide channels in a slot in the Hot Runner mainframe.
3. Slide the controller into the mainframe until the RMB connectors are firmly seated in the backplane of the mainframe.
4. Lock the controller into the frame by pressing in the plunger on the locking pin (or tighten the locking screw).

4.3 Apply Power to the Mainframe and Controller

When the controller is powered up, the output may be activated.

1. Before powering up the controller, consider the effects on your process if the output is activated. Take site-specific precautions.
2. Turn on the power to the mainframe.

3. Set the power switch on the front of the controller to on (I).

When the controller is powered up, all segments of the display and all LEDs light briefly, and then the firmware version number is displayed.

4.4 Adjust the Setpoint

When the controller is powered up, it will automatically do a CompuStep soft start for heater bake out if the process value is below 200 °F. (PV is on the top line of the display. SP is on the lower line.) During the soft start the NORMAL LED flashes.

During the soft start (which lasts five minutes or until the PV is 200 °F), adjust the setpoint to a value that is representative of the setpoint you expect to use when the controller is in service.²

To adjust the setpoint press the ▲ or ▼ key.

4.5 Wait for the Controller to Tune Itself

New RMB controllers are set to do a soft start every time they are powered up (if the PV is less than 200 °F), and then to do an Autotune operation each time the controller is powered up until a successful Autotune is completed.

If you are setting up a new process, Autotune all the RMB controllers in the process simultaneously, so that interactions between zones during tuning

² If the PV is greater than 200 °F, then the controller will skip the soft start, and will Autotune as soon as you power up the controller the first time. However, the tuning will not be valid, because you have not yet entered the appropriate setpoint for your process. Press **MODE** once to interrupt the Autotune. With the controller in normal mode (NORMAL LED lit), adjust the setpoint, and then cycle power to start Autotune again with a valid setpoint.

parallel the interactions expected while the controllers are in use.

If you need to stop the Autotune, press the **MODE** key until the controller is in standby. (When you are ready to Autotune, cycle the power to the controller.)

If you are installing a single replacement controller, let the Autotune proceed without interruption. During Autotune, the process value alternates with **tun**.

At the conclusion of a successful Autotune, the flashing **tun** disappears.

The display reverts to the normal mode operating display: PV on top line, SP on lower line. The proportional band and rate values calculated by the controller during the Autotune have been saved. (The integral (reset) action for PID control is always set to five times the rate value in an RMB controller.) Autotune is disabled. (If the Autotune is not successful, output goes to 0%, and you will see an error code; see 5.8.)

RMB controllers do not require calibration.

The controller is ready to use.

5. Error Messages and Codes

5.1 Introduction

Usually the controller displays the process variable on the top line and the setpoint on the lower line of the display. You can see other values on the lower line by pressing the **DISPLAY** key.

However, when the controller detects a problem with the input or output, or with its own operation, messages and codes are displayed to alert you to conditions that require your immediate attention.

5.2 Summary of Error Codes

If the controller detects a problem, the highest priority error will be displayed. The possible errors and suggested operator actions in response are summarized below.

When one of these error codes is displayed, the output is 0%. In the case of the **Out SHrt** (output short) and **bad Htr** (bad heater) errors, the output failure relay interrupts the output.

Displayed Code or Message	Error Condition	Operator Action
Highest Priority – Controller has detected a problem with its own operation. All errors of this type shut down controller activity (except for display of error message).		
Err 0100	PROM checksum error	Cycle power to clear the message. Note the error code and call for service.
Err 0101	RAM error	Cycle power to clear the message. Note the error code and call for service.
Err 0202	Default Pi d menu parameter values were loaded automatically, because the controller found corrupted values stored on the EEPROM. (This message is not displayed when you use SW2-switch 5 to set the default values intentionally.)	Cycle power to clear the message. Because the At.OP (Autotune operation) value will be set to "once", the controller will tune itself.

Displayed Code or Message	Error Condition	Operator Action
Err 0249	Calibration value corrupted.	Cycle power to clear the message. Note the error code and call for service.
Err 0303	EEPROM write failure occurred.	Cycle power to clear the message. Try again to save a Pi d menu parameter value. If the message recurs and persists, the EEPROM may be worn out. Call for service.
Err 2436	The controller could not determine whether the power frequency is 50 Hz or 60 Hz.	Cycle power to clear the message. Check the line frequency. If it is OK, but the message recurs and persists, call for service.
Err 3923 through 3543	Interrupt-related problem occurred.	Cycle power to clear the message. If the message recurs and persists, call for service.
<p>High Priority – PV is displayed on top line, unless an input error (medium priority) occurs simultaneously. In that case, the top line is blank; no valid PV is available. If two high priority error states are detected, the one ranked highest will be displayed on the lower line (see numbers below).</p>		
1) gFI	Hard ground fault detected (see 5.2).	Turn off controller. Fix the problem. Turn on the controller.
2) bAd Htr	Heater problem detected (see 5.7).	
3) Out SHrt	Output is off, but current flow is detected (see 5.7).	
4) LPbr	PV has not increased at least 1% of supported sensor span in 999 seconds (loop break time; see 5.4).	
5) Ht.rd Err	Heater conversion error occurred.	
<p>Medium Priority – SV is displayed on lower line. These conditions cannot occur simultaneously.</p>		
tC oPn	Thermocouple is open (see 5.5).	If the condition is fixed, the message will clear automatically. To clear the message manually, cycle the power.
tC rEu	Thermocouple leads are reversed (see 5.6).	
<p>Low Priority – SV is displayed on lower line. Output goes to 0%. Only one Autotune error will be displayed.</p>		
tun Er3 tun Er5 tun Er8 tun Er9	Autotune error; see 5.8 for details.	

5.3 Ground Fault in Controller Output Wiring

The RMB controller detects ground faults in the controller output wiring by monitoring the current to ground. If the current to ground is 55 mA or higher, the controller attempts to perform a normal soft start if the process value is less than or equal to 200 °F (93 °C). The standard CompuStep soft start described in 1.2 is executed. In this special case, the soft start will be executed up to three times. If the ground fault is still detected, the controller considers this a “hard” ground fault.

If a ground fault is detected when the process value is greater than 200 °F (93 °C), the controller considers it a “hard” ground fault immediately.

When a hard ground fault is detected, the controller:

- interrupts the signal to its own output, in effect “turning off” the output, and
- an error message GFI is displayed on the lower line, and
- the red ALARM LED lights (all other LEDs off).

Following the interrupt in response to a “hard” ground fault, the controller’s output remains off until you cycle power to the controller.

5.4 Loop Break in Sensor Wiring

If the input value does not change at least 1% of supported sensor span (9.67 °F or 5.37 °C) within 999 seconds while the controller output is on, and a “bad heater” error has not been detected (see 5.6), then:

- the controller output goes to 0%, and
- the red ALARM LED lights (all other LEDs off), and
- the message Lpbr is displayed on the lower line.

The controller remains in this alarm and output off state until you cycle power to the controller.

5.5 Open Thermocouple

If the controller detects an open sensor:

- the red ALARM LED lights (all other LEDs off), and
- the upper display alternates TC and oPn (open sensor), and
- the appropriate output action is taken, depending on control mode:
 - if the controller is in normal (auto) mode, the output goes to 0% for approximately one second, and then the controller uses a calculated output value, based on stored output values that have successfully maintained the current setpoint for your process in the past
 - if the controller is in manual mode, the output remains at the percent in use when the open sensor was detected

The controller remains in this alarm and failsafe state until the condition clears or you cycle power to the controller.

5.6 Reversed Thermocouple Leads

If the controller detects a reversed sensor:

- the controller output goes to 0%, and
- the red ALARM LED lights (all other LEDs off), and
- the upper display alternates TC and rEu (reversed sensor).

The controller remains in this alarm and output off state until the condition clears or you cycle power to the controller.

5.7 Heater Current Monitoring

The present current output to the heater, expressed to the closest tenth of an amp, is always displayable in the lower line. Cycle through the available lower line display items using the **DISPLAY** key. The controller constantly checks heater current readings to ensure that they correlate with output activity.

- If the output is off and a current flow greater than 0.1 amp is detected, then the controller posts a "TRIAC short" error.
- If the output is on, but no controller current output flow is detected, then the processor posts a "bad heater" error. (This condition is checked only if no loop break has been detected while the controller is in normal (auto) mode, and the PV is not within the proportional band.)

If either of these error conditions is detected:

- the output failure interruption relay breaks the connection between the controller's TRIAC output and the heater, and

- controller processing stops, and
- the red ALARM LED lights (all other LEDs off), and
- an alarm message is displayed on the lower line:
- if a short was detected, **Out** alternates with **SHrt**
- if a heater problem is detected, **bAd** alternates with **Htr**

The controller remains in this halted state until you cycle power to the controller.

5.8 Autotune Errors

At the conclusion of an unsuccessful Autotune, you will see **Er** plus a one-digit error code (alternating with **tun**). If the Autotune is not successfully completed, the Autotune feature is not disabled automatically.

An Autotune error code is displayed until you press the **MODE** key. If the Autotune operation is terminated by the controller because of an error condition, the controller output goes to 0%.

Autotune Errors	
Error Code	Description
Er3	Setpoint is higher than the process value. Look at the setpoint. If it is realistic for your process, then check the thermocouple leads; maybe they are reversed.
Er5	There is not enough difference between initial PV and the setpoint. For Autotune to work, the difference must be at least 9 °F (5 °C).
Er8	The startup curve (change in PV) was not acceptable to the Autotune algorithm. This could be caused by a process upset that occurred during tuning. Try Autotuning again when the process is stable. If the error recurs, your process is not suitable for Autotuning. Use manual tuning; see 2.4.
Er9	The Autotuning timed out, because the process was unresponsive (or extremely slow). Your process is not suitable for Autotuning. Use manual tuning; see 2.4.

6. Maintenance

6.1 Introduction

This section contains instructions for cleaning the front panel of the controller and instructions for replacing the fuses.

Except for fuses, the controller contains no user-serviceable parts.

Warning



Do not attempt to clean any part of a controller other than the front panel.

If you want to clean the front panel of a single controller, use the power switch on the front of the controller to turn it off, then remove the controller from the mainframe.

If you want to clean the front panel of several controllers, turn off all controllers in the mainframe and turn off power to the mainframe before cleaning the controllers while they are in the mainframe.

While cleaning a controller's front panel, do not allow alcohol to enter the switch.

Allow controllers and mainframes to dry thoroughly before restoring power. Do not use a heater or compressed air to dry the units.

Failure to observe these precautions can result in exposure to a potentially lethal shock hazard.

The controller power switch should be in the "OFF" position before you put a controller into an energized mainframe, or remove a controller from an energized mainframe. Failure to observe these precautions can result in damage to the connectors and printed circuit boards.

6.2 Cleaning the Front Panel

To clean an RMB controller:

1. Read the safety warnings above before you start cleaning a controller.
2. To clean the front panel of a single controller, put the controller power switch in the "OFF" position, and then remove the controller from the energized mainframe by pulling out the plunger on the locking pin (or

loosening the locking screw), and pulling on the handle on the front of the controller.

Alternatively, if you plan to clean the front panel of several controllers, put the power switch of every controller in the mainframe in the "OFF" position, and then turn off power to the entire mainframe. After the mainframe has been de-energized, you can clean the controllers while they are in the mainframe.

3. Use a cotton cloth to gently and sparingly apply isopropyl alcohol to the front panel of the controller. Do not use cleaning solutions or other solvents. Use of anything other than isopropyl alcohol can result in damage to the controller.

Do not allow alcohol to enter the power switch on the controller's front panel.

4. Allow the controller to air-dry thoroughly. Do not use a heater or compressed air to dry the unit.
5. Inspect all surfaces to make sure that they are completely dry.
6. When the controller is completely dry, re-install it and return it to service.

6.3 Replacing the Fuses

Each RMB controller with 15 amp output contains two fuses, located on the main printed circuit board. An RMB with 30 amp output has one fuse on the main circuit board.

To replace the fuses in an RMB controller:

1. Make sure that you have the correct replacement fuse.
 - For RMB controller with 15 amp output – Type F fast-acting 250 Vac fuses rated at 15 amps. Suitable fuses are p/n 210B001U01 and Littlefuse Inc. p/n 314015.
 - For RMB controller with 30 amp output – Type F fast-acting 250 Vac fuse rated at 30 amps. Suitable fuses are p/n 210A009U01 and Cooper Bussmann FWX-30A14FB.
2. Put the power switch of the controller in the "OFF" position.
3. Pull out the plunger in the locking pin (or loosen the locking screw).

4. Use the handle on the front of the controller to pull it out of the mainframe.
5. Replace the fuses.
6. Re-install the controller and return it to service.

6.4 Unit Repairs

It is recommended that units requiring service be returned to an authorized service center. Before a controller is returned for service, please consult the service center nearest you. In many cases, the problem can be cleared up over the telephone. When the unit needs to be returned, the service center will ask for a detailed explanation of problems encountered and a Purchase Order to cover any charge. This information should also be put in the box with the unit. This should expedite return of the unit to you.

7. Frequently Asked Questions

7.1 Introduction

Before you call for technical support, please look at this section to see if your question is covered here. If you do call for technical assistance, be ready to supply the following information:

- complete model number of controller (and firmware version if known)
- symptoms of the problem
- unusual events, if any, that preceded the problem
- remedies you have already tried

7.2 FAQs

7.2.1 How do I change from a J to a K thermocouple?

Every Series RMB controller is shipped ready to accept input from a J thermocouple. If you plan to use a K thermocouple for input, you must set SW2-switch 2 to ON as described in Section 3. **Read the safety warnings at the front of this manual before changing switch settings.**

7.2.2 Do I have to calibrate a new controller?

No

7.2.3 Why doesn't the displayed PV match the value on a thermometer in the process?

Unless the thermometer and the sensor providing input to the controller are very close to one another, their readings will not match in some applications, because of temperature variations within the process.

7.2.4 I turned on the power; why doesn't the controller light up?

If SafeChange is enabled, but the mainframe does not support SafeChange, the controller will not work. Instructions for checking to see if a mainframe supports SafeChange are in 3.2.

Index

A

alarms, 2, 5, 6
At.OP parameter, 6, 7, 12
automatic mode. *See* normal mode
Autotune, 2, 6, 7, 11
Autotune errors, 13, 15
Autotune Operation parameter, 6, 7, 12

B

bad Htr error message, 15
boost, 5, 7
bumpless transfer, 6

C

calibration, 12, 18
calibration value corrupted error, 13
CE EMC compliance, 11
changing setpoint or output, 7
checksum error, 12
cleaning controllers, 16
CompuStep, 2, 3
current displayed, 3, 7
current monitoring, 3, 15

D

default switch settings, 10
default values, 12
derivative action, 2, 7, 12
deviation alarms, 2, 5, 6
DISPLAY key, 5
displays, 5, 12

E

EEPROM write error, 13
error codes, 12

F

factory default switch settings, 10
factory default values, 12
front panel, 5
fuses, 17

G

gFI error message, 14
ground fault detection, 3, 14

H

HEAT LED, 5, 6
heater conversion error, 13
heater current display, 7
heater current monitoring, 3
HT.rd Err message, 13

I

input failure, 14
input switch setting, 3, 18
integral action, 2, 7, 12
interrupt (unexpected or invalid), 13

J

J thermocouple, switch setting for, 3, 10, 18
jumper setting, 9

K

K thermocouple, switch setting for, 3, 10, 18

L

line frequency determination error, 13
loop break, 3, 14
LPbr error message, 3, 14

M

maintenance, 16
MANUAL LED, 5
manual tuning, 7
MODE key, 5
modes of operation, 2, 6

N

NORMAL LED, 5
normal mode, 2

O

open sensor, 14
Out Shrt error message, 15
output bad, 3, 15
output displayed, 7
output for control, 2, 6
output in manual mode, 7
output state on power up, 6
output TRIAC short error, 3, 15

P

part number for fuses, 17
part number for SafeChange clip, 10
Pid menu, 2, 6, 7, 12, 13
powering up controller, 6
process value display, 5, 6
proportional band, 2, 7, 12

R

RAM error, 12
rate, 2, 7, 12
replacing fuses, 17
reset, 7, 12
reversed sensor, 14

S

SafeChange feature, 9, 18
safety information, I, 16
sensor error, 3
sensor type, switch setting for, 3, 18
setpoint, 5, 7
soft start, 2, 3
span calibration, 18
STANDBY LED, 5
switch settings, 3, 9, 10, 18

T

tC oPn error message, 14
tC rEv error message, 14
technical support, 18
TRIAC short error message, 3, 15
troubleshooting, 12, 18
tuning, 7, 11

U

unit of measure switch setting, 9, 10
user interface, 5
user-serviceable parts, 16

Z

zero calibration, 18

Two-Year Limited Warranty

THIS EQUIPMENT IS WARRANTED TO BE FREE FROM DEFECTS OF MATERIAL AND WORKMANSHIP. IT IS SOLD SUBJECT TO OUR MUTUAL AGREEMENT THAT THE LIABILITY OF ATHENA CONTROLS, INCORPORATED IS TO REPLACE OR REPAIR THIS EQUIPMENT AT ITS FACTORY, PROVIDED THAT IT IS RETURNED WITH TRANSPORTATION PREPAID WITHIN TWO (2) YEARS OF ITS PURCHASE.

THE PURCHASER AGREES THAT ATHENA CONTROLS, INCORPORATED ASSUMES NO LIABILITY UNDER ANY CIRCUMSTANCES FOR CONSEQUENTIAL DAMAGES RESULTING FROM ITS USE OR FROM IMPROPER HANDLING OR PACKAGING OF SHIPMENTS RETURNED TO THE FACTORY.

COMPONENTS WHICH WEAR OR WHICH ARE DAMAGED BY MISUSE ARE NOT WARRANTED. THESE INCLUDE CONTACT POINTS, FUSES, ELECTROMECHANICAL RELAYS, AND TRIACS. UNITS WHICH HAVE BEEN MODIFIED BY A CUSTOMER IN ANY WAY ARE NOT WARRANTED.

Other than those expressly stated herein, THERE ARE NO OTHER WARRANTIES OF ANY KIND, EXPRESS OR IMPLIED, AND SPECIFICALLY EXCLUDED BUT NOT BY WAY OF LIMITATION, ARE THE IMPLIED WARRANTIES OF FITNESS FOR A PARTICULAR PURPOSE AND MERCHANTABILITY.

IT IS UNDERSTOOD AND AGREED THE SELLER'S LIABILITY WHETHER IN CONTRACT, IN TORT, UNDER ANY WARRANTY, IN NEGLIGENCE OR OTHERWISE SHALL NOT EXCEED THE RETURN OF THE AMOUNT OF THE PURCHASE PRICE PAID BY THE PURCHASER AND UNDER NO CIRCUMSTANCES SHALL SELLER BE LIABLE FOR SPECIAL, INDIRECT, INCIDENTAL OR CONSEQUENTIAL DAMAGES. THE PRICE STATED FOR THE EQUIPMENT IS A CONSIDERATION IN LIMITING SELLER'S LIABILITY. NO ACTION, REGARDLESS OF FORM, ARISING OUT OF THE TRANSACTIONS OF THIS AGREEMENT MAY BE BROUGHT BY PURCHASER MORE THAN ONE YEAR AFTER THE CAUSE OF ACTION HAS ACCRUED.

SELLER'S MAXIMUM LIABILITY SHALL NOT EXCEED AND BUYER'S REMEDY IS LIMITED TO EITHER (i) REPAIR OR REPLACEMENT OF THE DEFECTIVE PART OR PRODUCT, OR AT SELLER'S OPTION (ii) RETURN OF THE PRODUCT AND REFUND OF THE PURCHASE PRICE, AND SUCH REMEDY SHALL BE BUYER'S ENTIRE AND EXCLUSIVE REMEDY. THE SPECIFICATIONS PUT FORTH IN THIS MANUAL ARE SUBJECT TO CHANGE WITHOUT NOTICE.

***For free technical assistance in the U.S.,
call toll free 1-800-782-6776 or
email techsupport@athenacontrols.com***



Athena Controls, Inc • 5145 Campus Drive • Plymouth Meeting, PA 19462 USA
Tel: 610-828-2490 • Fax: 610-828-7084 • techsupport@athenacontrols.com • athenacontrols.com